



STI 9

Edition 2/October 2000

Interface technical specifications
for France Telecom's network

Directive 1999/5/EC

Characteristics of 2-wire/4-wire analogue leased link service access interfaces

Summary: This document gives a brief description of the 2-wire/4-wire analogue leased link services, and describes the technical characteristics of the interfaces used for accessing these services.

Warning :

"Only the French text is authentic; therefore France Telecom accepts no responsibility or liability whatsoever with regard to any information or data referred to in this document".

France Telecom
6, Place d'Alleray
75505 Paris Cedex 15

<http://www.francetelecom.com>

Notice

Information enclosed in this document is at terminal equipment manufacturers' disposal, pursuant to Directive 1999/5/EC of the European Parliament and of the Council of 9 March 1999 on radio equipment and telecommunications terminal equipment and the mutual recognition of their conformity.

According to Directive 1999/5/EC and specially Article 4.2, France Telecom reserves the right to modify or complement the information contained in this document in order to update the interface technical specifications and to allow the creation of telecommunication terminal equipments capable of using the services provided by the corresponding interfaces.

France Telecom can be held responsible neither for non-operation or poor operation of a terminal equipment, if the equipment complies with this specification, nor for any damage resulting from the use or misuse of the information contained in this document, towards whoever it be.

Provision of these technical specifications results in no transfer of rights, no granting of license on any intellectual property right, belonging to France Telecom.

France Telecom holds exclusive rights on France Telecom brands mentioned in this document.

France Telecom further points out users' attention on the following points:

1. timer values are indicative and can be subject to modification,
2. due to various technical constraints, some services or service options may not be available on some interfaces,
3. the fact that a service not yet commercially open is described in this document can in no case be considered as a binding commitment on France Telecom part to actually open this service.

Table of contents

1. TELEPHONE LINKS AND TELEGRAPH LINKS: OVERVIEW OF SERVICES	1
1.1 ORDINARY QUALITY 2-WIRE TELEPHONE LEASED LINK (ITU-T M.1040)	1
1.1.1 Definition of the service	1
1.1.2 Connection interface	1
1.1.3 Transmission characteristics measured at termination points	1
1.2 ORDINARY QUALITY 4-WIRE TELEPHONE LEASED LINK (ITU-T M.1040)	2
1.2.1 Definition of the service	2
1.2.2 Connection interface	2
1.2.3 Transmission characteristics measured at termination points	2
1.3 SPECIAL QUALITY 2-WIRE TELEPHONE LEASED LINK (ITU-T M.1020)	2
1.3.1 Definition of the service	2
1.3.2 Connection interface	2
1.3.3 Transmission characteristics measured at termination points	2
1.4 SPECIAL QUALITY 4-WIRE TELEPHONE LEASED LINK (ITU-T M.1020)	3
1.4.1 Definition of the service	3
1.4.2 Connection interface	3
1.4.3 Transmission characteristics measured at termination points	3
1.5 TELEGRAPH LEASED LINK	4
1.5.1 Definition of the service	4
1.5.2 Connection interface	4
1.5.3 Transmission characteristics measured at termination points	4
2. SOUND-PROGRAMME QUALITY BROADBAND LEASED LINKS: OVERVIEW OF SERVICES.....	4
2.1 MONOPHONIC 7 KHZ SOUND-PROGRAMME QUALITY BROADBAND LEASED LINK	4
2.1.1 Definition of the service	4
2.1.2 Connection interface	4
2.1.3 Transmission characteristics	4
2.2 MONOPHONIC 15 KHZ SOUND-PROGRAMME QUALITY BROADBAND LEASED LINK	5
2.2.1 Definition of the service	5
2.2.2 Connection interface	5
2.2.3 Transmission characteristics	5
2.3 STEREOPHONIC 15 KHZ SOUND-PROGRAMME QUALITY BROADBAND LEASED LINK	6
2.3.1 Definition of the service	6
2.3.2 Connection interface	6
2.3.3 Transmission characteristics	6
3. HISTORY	6
APPENDIX 1: TEMPLATE ASSOCIATED WITH RECOMMENDATION M.1040	7
APPENDIX 2: TEMPLATES ASSOCIATED WITH RECOMMENDATION M.1020	8
APPENDIX 3: TEMPLATES ASSOCIATED WITH MONOPHONIC 7 KHZ SOUND-PROGRAMME QUALITY BROADBAND LINK.....	9
APPENDIX 4: TEMPLATES ASSOCIATED WITH MONOPHONIC 15 KHZ SOUND-PROGRAMME QUALITY BROADBAND LINK.....	10
APPENDIX 5: SPECIAL CHARACTERISTICS OF STEREOPHONIC 15 KHZ SOUND-PROGRAMME QUALITY BROADBAND LINKS	11

Please note: All of the values given in this document are measured at the termination points that are represented, at each end of the link, by the user access.

1. TELEPHONE LINKS AND TELEGRAPH LINKS: OVERVIEW OF SERVICES

The provision of an analogue leased link involves France Telecom providing a permanent transmission capacity between two identified, fixed points. The quality of the transmission medium depends on the type of link.

The France Telecom catalogue offers the following analogue leased links:

- Ordinary quality 2-wire telephone leased link (ITU-T M.1040)
- Ordinary quality 4-wire telephone leased link (ITU-T M.1040)
- Special quality 2-wire telephone leased link (ITU-T M.1020)
- Special quality 4-wire telephone leased link (ITU-T M.1020)

and:

- Monophonic 7 kHz sound-programme quality broadband leased link (ITU-T N.10)
- Monophonic 15 kHz sound-programme quality broadband leased link (ITU-T N.10)
- Stereophonic 15 kHz sound-programme quality broadband leased link (ITU-T N.10)

This document gives the characteristics of these products, along with the associated connection and environmental conditions.

1.1 ORDINARY QUALITY 2-WIRE TELEPHONE LEASED LINK (ITU-T M.1040)

1.1.1 DEFINITION OF THE SERVICE

Ordinary quality 2-wire telephone links are used to transmit electric signals in the voice band (300 - 3400 Hz), between two fixed connection interfaces represented by testing devices. They can only be established in a point-to-point configuration.

1.1.2 CONNECTION INTERFACE

The connection interface available on the testing device, delivered as a screw terminal block, is composed of two wires.

1.1.3 TRANSMISSION CHARACTERISTICS MEASURED AT TERMINATION POINTS

- a) Transmission between the two termination points, including signalling, is always in the standardised frequency band 300 - 3400 Hz (voice band).
- b) The attenuation value between the two termination points, measured on a 600 Ohm characteristic impedance and at the 1020 Hz reference frequency, does not exceed 15 dB.
- c) The variation of the attenuation of a link between the two termination points, with 600 Ohm characteristic impedance, measured according to the frequency, in the voice band and in relation to the overall loss at 1020 Hz, does not exceed the maximum values given in the template in Appendix 1.
- d) The average psophometric noise voltage measured on 600 Ohm characteristic impedance carried to a point with relative value 0 does not exceed - 38 dBm0p.
- e) The relative sound level at the termination point is fixed at 4 dBr.
- f) With data transmission, the maximum send signal power level must be equal to or less than - 13 dBmo.

1.2 ORDINARY QUALITY 4-WIRE TELEPHONE LEASED LINK (ITU-T M.1040)

1.2.1 DEFINITION OF THE SERVICE

Ordinary quality 4-wire telephone links are used to transmit electric signals in the voice band (300 - 3400 Hz), between two fixed connection interfaces represented by testing devices. They can be established in a point-to-point or a point-to-multipoint configuration.

1.2.2 CONNECTION INTERFACE

The connection interface available on the testing device, delivered as a screw terminal block, is composed of four wires: a transmission pair and a reception pair.

1.2.3 TRANSMISSION CHARACTERISTICS MEASURED AT TERMINATION POINTS

- a) Transmission between the two termination points, including signalling, is always in the standardised frequency band 300 - 3400 Hz (voice band).
- b) The attenuation value between the two termination points, measured on a 600 Ohm characteristic impedance and at the 1020 Hz reference frequency, does not exceed 15 dB.
- c) The variation of the attenuation of a link between the two termination points, with 600 Ohm characteristic impedance, measured according to the frequency, in the voice band and in relation to the overall loss at 1020 Hz, does not exceed the maximum values given in the template in Appendix 1.
- d) The average psophometric noise voltage measured on 600 Ohm characteristic impedance carried to a point with relative value 0 does not exceed - 38 dBm0p.
- e) The relative sound level at the termination point is fixed at 0 dBr.
- f) With data transmission, the maximum send signal power level for transmission must be equal to or less than - 13 dBm0.

1.3 SPECIAL QUALITY 2-WIRE TELEPHONE LEASED LINK (ITU-T M.1020)

1.3.1 DEFINITION OF THE SERVICE

Special quality 2-wire telephone links are used to transmit electric signals in the voice band (300 - 3400 Hz), between two fixed connection interfaces represented by testing devices. They can only be established in a point-to-point configuration.

1.3.2 CONNECTION INTERFACE

The connection interface available on the testing device, delivered as a screw terminal block, is composed of two wires.

1.3.3 TRANSMISSION CHARACTERISTICS MEASURED AT TERMINATION POINTS

- a) Transmission between the two termination points, including signalling, is always in the standardised frequency band 300 - 3400 Hz (voice band).
- b) The attenuation value between the two termination points, measured on a 600 Ohm characteristic impedance and at the 1020 Hz reference frequency, does not exceed 13 dB.
- c) After link commissioning, the variation of the value above will not exceed ± 4 dB.
- d) The variation of the attenuation of a link between the two termination points, with 600 Ohm characteristic impedance, measured according to the frequency, in the voice band and in relation to the overall loss at 1020 Hz, does not exceed the maximum values given in the template in Appendix 2.
- e) The average psophometric noise voltage measured on 600 Ohm characteristic impedance carried to a point with relative value 0 does not exceed - 38 dBm0p.

- f) The number of impulsive noise bursts of a level greater than - 21 dBm0 does not exceed 18 in a 15-minute measurement period.
- g) The group delay distortion does not exceed the maximum values given in the template in Appendix 2.
- h) The signal-to-total distortion ratio is greater than 28 dB if a - 10 dBm0 measuring sinewave is used.
- i) With data transmission, the maximum send signal power level must be equal to or less than - 13 dBm0.
- j) The relative sound level at the termination point is fixed at 4 dBr.

1.4 SPECIAL QUALITY 4-WIRE TELEPHONE LEASED LINK (ITU-T M.1020)

1.4.1 DEFINITION OF THE SERVICE

Special quality 4-wire telephone links are used to transmit electric signals in the voice band (300 - 3400 Hz), between two fixed connection interfaces represented by testing devices. They can be established in a point-to-point or a point-to-multipoint configuration.

1.4.2 CONNECTION INTERFACE

The connection interface available on the testing device, delivered as a screw terminal block, is composed of four wires: a transmission pair and a reception pair.

1.4.3 TRANSMISSION CHARACTERISTICS MEASURED AT TERMINATION POINTS

- a) Transmission between the two termination points, including signalling, is always in the standardised frequency band 300 - 3400 Hz (voice band).
- b) The attenuation value between the two termination points, measured on a 600 Ohm characteristic impedance and at the 1020 Hz reference frequency, does not exceed 13 dB.
- c) After link commissioning, the variation of the value above will not exceed ± 4 dB.
- d) The variation of the attenuation of a link between the two termination points, with 600 Ohm characteristic impedance, measured according to the frequency, in the voice band and in relation to the overall loss at 1020 Hz, does not exceed the maximum values given in the template in Appendix 2.
- e) The average psophometric noise voltage measured on 600 Ohm characteristic impedance carried to a point with relative value 0 does not exceed - 38 dBm0p.
- f) The number of impulsive noise bursts of a level greater than - 21 dBm0 does not exceed 18 in a 15-minute measurement period.
- g) The group delay distortion complies with the template in Appendix 2.
- h) The signal-to-total distortion ratio is greater than 28 dB if a - 10 dBm0 measuring sinewave is used.
- i) With data transmission, the maximum send signal power level must be equal to or less than - 13 dBm0.
- j) The relative sound level at the termination point is fixed at 0 dBr.

1.5 TELEGRAPH LEASED LINK

1.5.1 DEFINITION OF THE SERVICE

Telegraph links are used to exchange the frequencies defined in ITU-T Recommendation R.20 only. They can be established in a point-to-point or a point-to-multipoint configuration. Point-to-multipoint configuration is operated in one way only, and there is either broadcast only or concentration only.

1.5.2 CONNECTION INTERFACE

The connection interface available on the testing device, delivered as a screw terminal block, is composed of two wires.

1.5.3 TRANSMISSION CHARACTERISTICS MEASURED AT TERMINATION POINTS

The transmission characteristics of a telegraph link are identical to those of a 2-wire telephone link, described in section 1.1.3.

The code/rate pairs that can be used are defined in ITU-T Recommendation R.101, variant B.

2. SOUND-PROGRAMME QUALITY BROADBAND LEASED LINKS: OVERVIEW OF SERVICES

Sound-programme quality broadband links are composed of a one-way communication channel. There are three types of broadband links according to the transmission type:

- monophonic medium quality transmission in the 50 - 7000 Hz frequency band,
- monophonic high quality transmission in the 40 - 15,000 Hz frequency band,
- stereophonic high quality transmission in the 40 - 15,000 Hz frequency band.

These links comply with ITU-T Recommendation N.10.

2.1 MONOPHONIC 7 KHZ SOUND-PROGRAMME QUALITY BROADBAND LEASED LINK

2.1.1 DEFINITION OF THE SERVICE

Monophonic 7 kHz sound-programme quality broadband links are used for one-way transmission in the 50 - 7000 Hz frequency band.

2.1.2 CONNECTION INTERFACE

The connection interface available on the testing device, delivered as a screw terminal block, is composed of two wires.

2.1.3 TRANSMISSION CHARACTERISTICS

- a) Each end must have, on a permanent basis, one 40 - 15,000 Hz modulation transformer per channel, and only transmit with an output impedance below 20 Ohms.
- b) The composite attenuation value between the two termination points, measured on a 600 Ohm impedance and at the 1020 Hz reference frequency, does not exceed 6 dB.
- c) After monophonic link commissioning, none of the measurements taken on the source termination point exceed the theoretical reference radio send level fixed at +6 dBm, i.e. 0 dBm0s.
- d) After commissioning, the customer is expected to respect a maximum transmitted absolute power level of +15 dBm, i.e. +9 dBm0s at all times.

- e) The variation of the composite attenuation of a link between the two termination points, with 600 Ohm characteristic impedance, according to the frequency, in the 50 - 7000 Hz frequency band, does not exceed the maximum values given in the template in Appendix 3.
- f) The group delay distortion complies with the template in Appendix 3.
- g) The average psophometric noise voltage measured on 600 Ohm characteristic impedance carried to a point with relative value 0 does not exceed - 51 dBq0ps.
- h) The total harmonic distortion at the maximum sound level, +15 dBm, must not exceed 2% at 60 Hz or 1.4% at 1020 Hz.

2.2 MONOPHONIC 15 KHZ SOUND-PROGRAMME QUALITY BROADBAND LEASED LINK

2.2.1 DEFINITION OF THE SERVICE

Monophonic 15 kHz sound-programme quality broadband links are used for one-way transmission in the 40 – 15,000 Hz frequency band.

2.2.2 CONNECTION INTERFACE

The connection interface available on the testing device, delivered as a screw terminal block, is composed of two wires.

2.2.3 TRANSMISSION CHARACTERISTICS

- a) Each end must have, on a permanent basis, one 40 - 15,000 Hz modulation transformer per channel, and only transmit with an output impedance below 20 Ohms.
- b) The composite attenuation value between the two termination points, measured on a 600 Ohm impedance and at the 1020 Hz reference frequency, does not exceed 6 dB.
- c) After monophonic link commissioning, none of the measurements taken on the source termination point exceed the theoretical reference radio send level fixed at +6 dBm, i.e. 0 dBm0s.
- d) After commissioning, the customer is expected to respect a maximum transmitted absolute power level of +15 dBm, i.e. +9 dBm0s at all times.
- e) The variation of the composite attenuation of a link between the two termination points, with 600 Ohm characteristic impedance, according to the frequency, in the 40 - 15,000 Hz frequency band, does not exceed the maximum values given in the template in Appendix 4.
- f) The group delay distortion complies with the template in Appendix 4.
- g) The average psophometric noise voltage measured on 600 Ohm characteristic impedance carried to a point with relative value 0 does not exceed - 51 dBq0ps.
- h) The total harmonic distortion at the maximum sound level, +15 dBm, must not exceed 1.2% at 60 Hz or 0.6% at 1020 Hz.

2.3 STEREOPHONIC 15 KHZ SOUND-PROGRAMME QUALITY BROADBAND LEASED LINK

2.3.1 DEFINITION OF THE SERVICE

Stereophonic 15 kHz sound-programme quality broadband links are used for one-way transmission in the 40 - 15,000 Hz frequency band.

2.3.2 CONNECTION INTERFACE

The connection interface available on the testing device, delivered as a screw terminal block, is composed of four wires.

2.3.3 TRANSMISSION CHARACTERISTICS

- a) Each end must have, on a permanent basis, one 40 - 15,000 Hz modulation transformer per channel, and only transmit with an output impedance below 20 Ohms.
- b) The composite attenuation value between the two termination points, measured on a 600 Ohm impedance and at the 1020 Hz reference frequency, does not exceed 6 dB.
- c) After stereophonic link commissioning, none of the measurements taken on the source termination point exceed the theoretical reference radio send level fixed at +6 dBm, i.e. 0 dBm0s.
- d) After commissioning, the customer is expected to respect a maximum transmitted absolute power level of +15 dBm, i.e. +9 dBm0s at all times.
- e) The variation of the composite attenuation of a link between the two termination points, with 600 Ohm characteristic impedance, according to the frequency, in the 40 - 15,000 Hz frequency band, does not exceed the maximum values given in the template in Appendix 4.
- f) The group delay distortion complies with the template in Appendix 4.
- g) The average psophometric noise voltage measured on 600 Ohm characteristic impedance carried to a point with relative value 0 does not exceed - 51 dBq0ps.
- h) The total harmonic distortion at the maximum sound level, +15 dBm, must not exceed 1.2% at 60 Hz or 0.6% at 1020 Hz.
- i) The absolute value of the gain difference between stereophonic channels A and B complies with the template in Appendix 5.
- j) The measurement of the phase difference between stereophonic channels A and B complies with the template in Appendix 5.
- k) The crosstalk ratio between stereophonic channels A and B must be greater than 58 dB.

3. HISTORY

Edition	Date	Comments
1	March 2000	First version
2	October 2000	Title changed and minor modifications made

Appendix 1: Template associated with Recommendation M.1040

M.1040 – Maximum overall loss of circuit in relation to overall loss at 1020 Hz

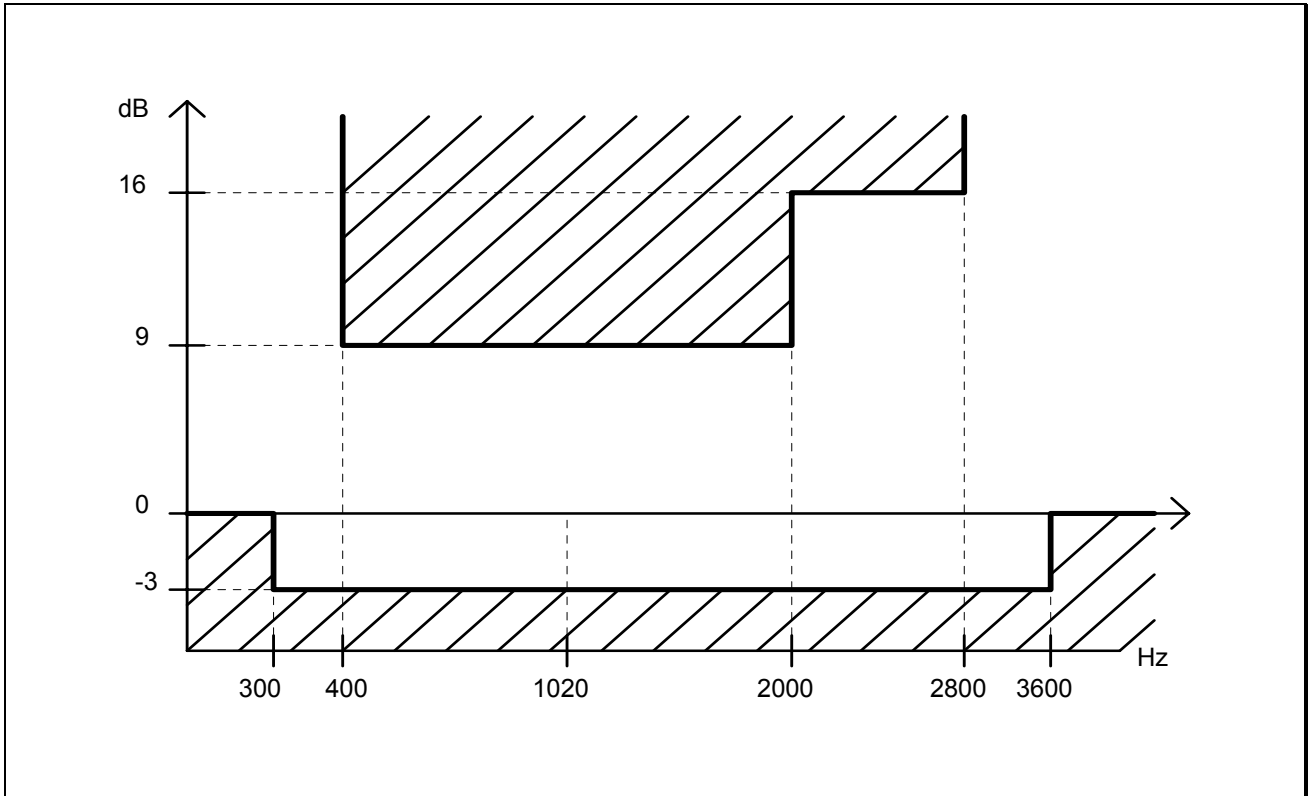

Note: The template is only guaranteed to be respected in the 300 - 3400 Hz frequency band.

Appendix 2: Templates associated with Recommendation M.1020

M.1040 – Maximum overall loss of circuit in relation to overall loss at 1020 Hz

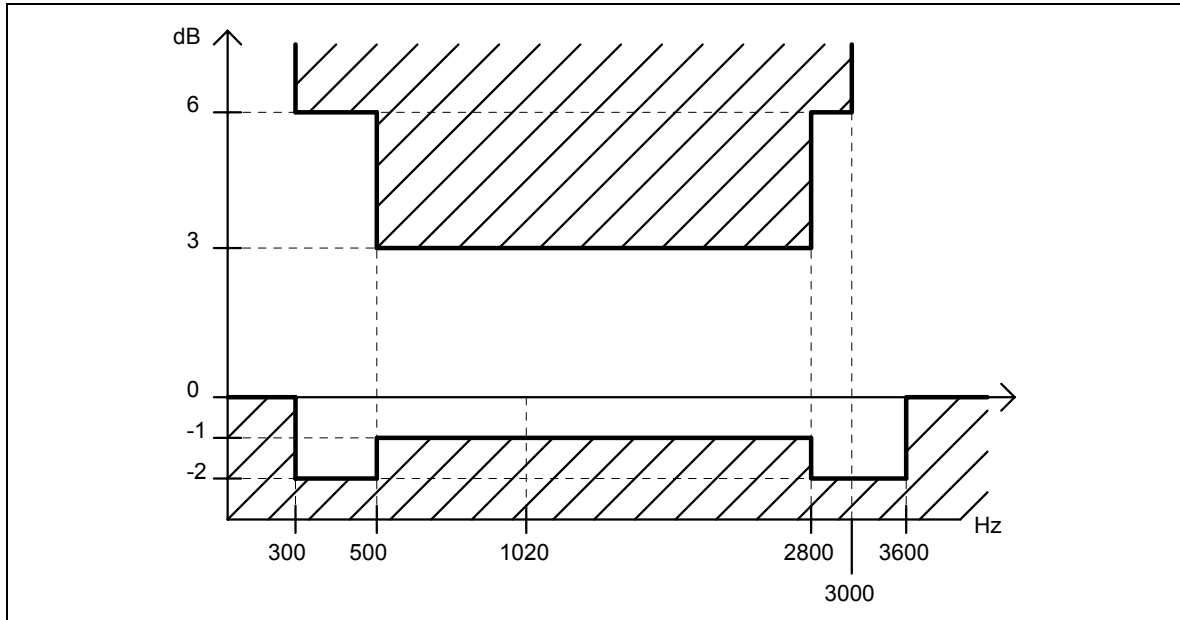

Note: The template is only guaranteed to be respected in the 300 - 3400 Hz frequency band.

M.1020 – Maximum group delay in relation to minimum value measured in
500 - 2800 Hz frequency band

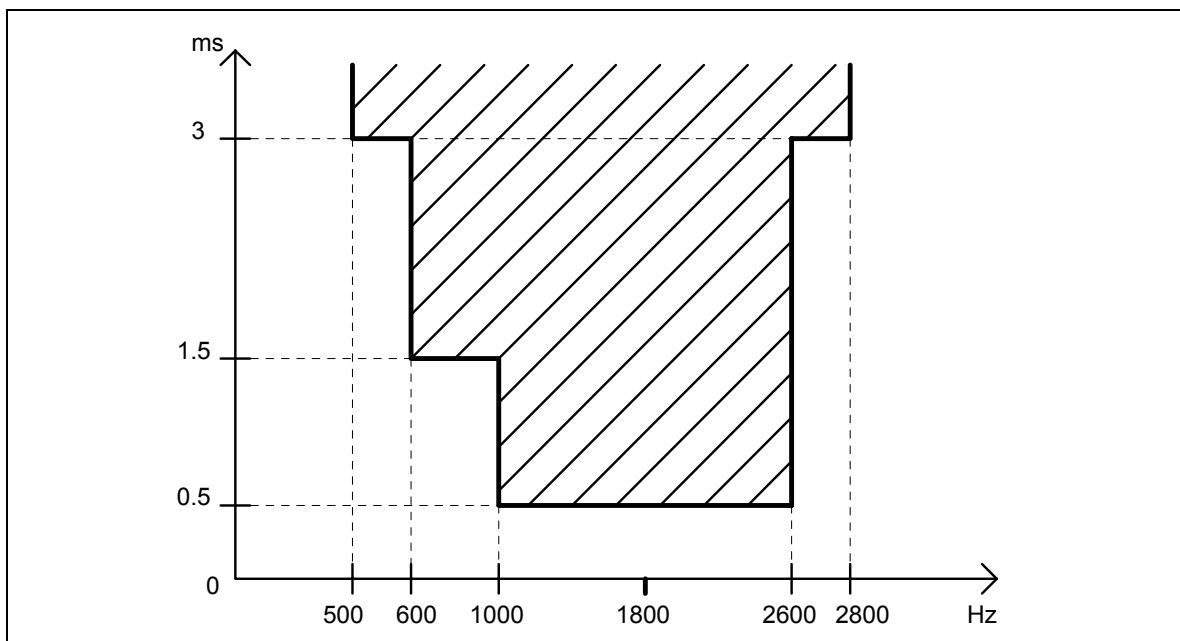

Appendix 3: Templates associated with monophonic 7 kHz sound-programme quality broadband link

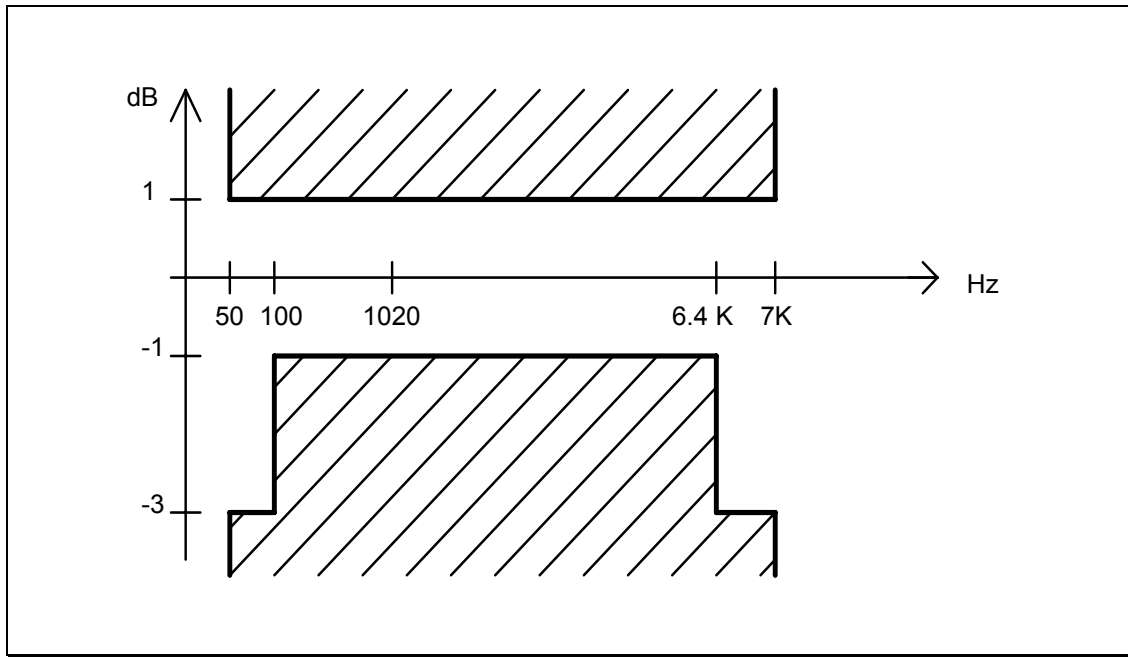

Monophonic 7 kHz sound-programme quality broadband link – Maximum attenuation distortion values according to frequency

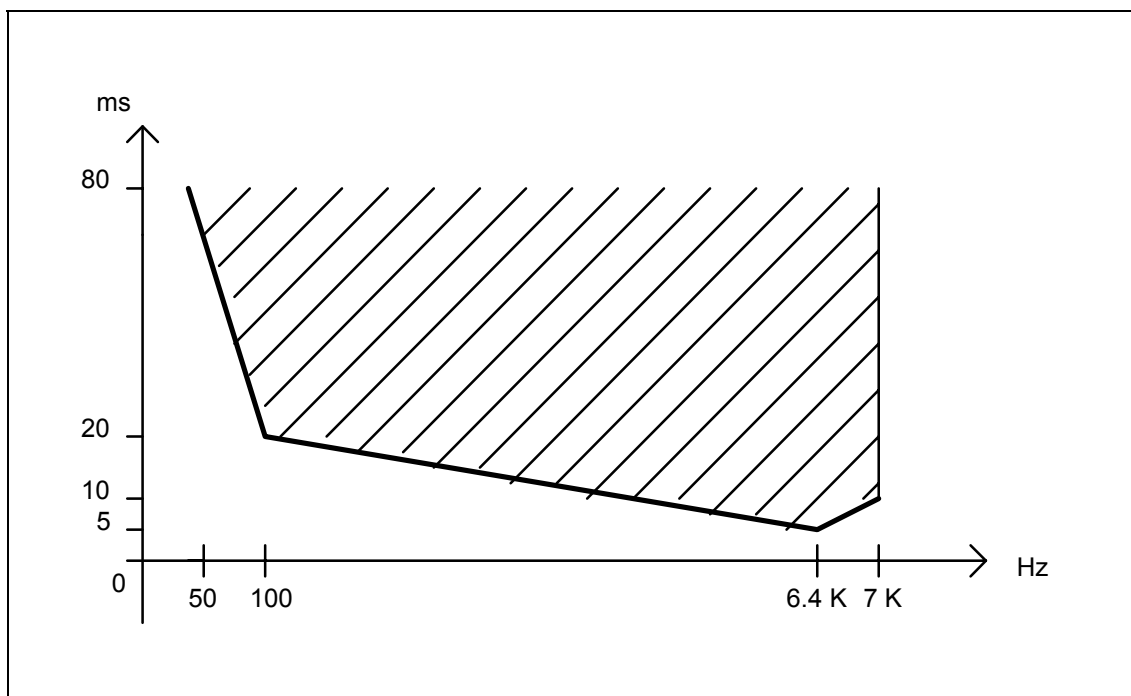

Monophonic 7 kHz sound-programme quality broadband link - Maximum group delay distortion values according to frequency

Appendix 4: Templates associated with monophonic 15 kHz sound-programme quality broadband link

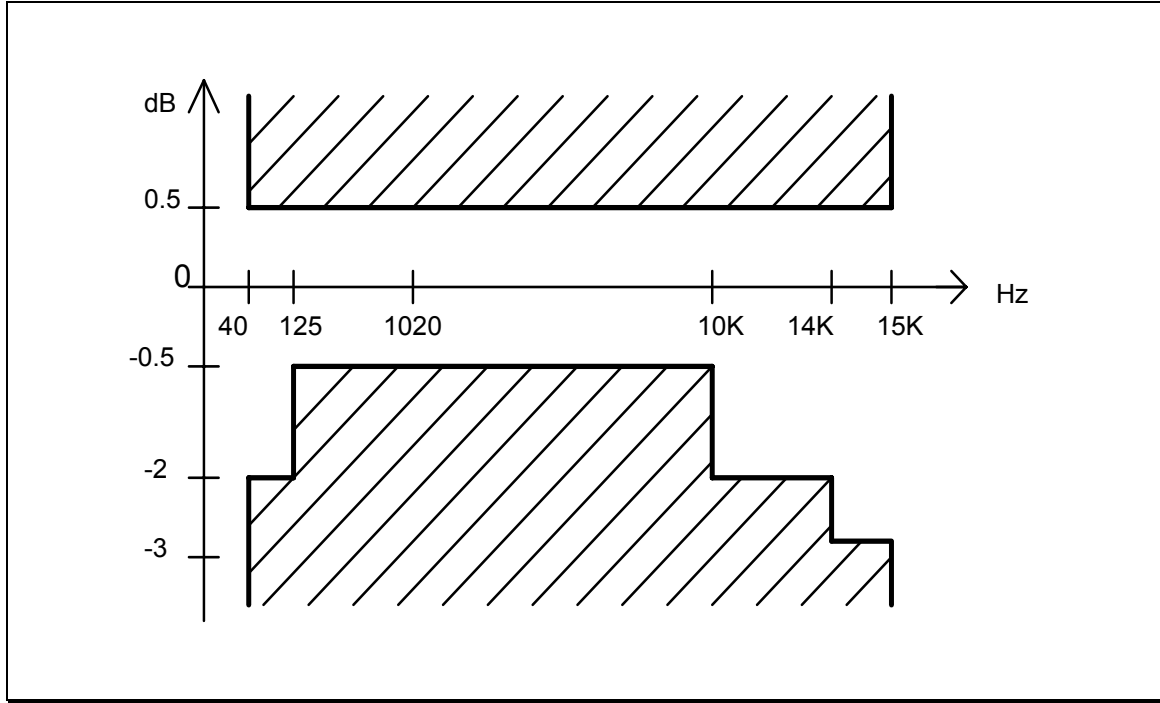

Monophonic 15 kHz sound-programme quality broadband link – Maximum attenuation distortion values according to frequency

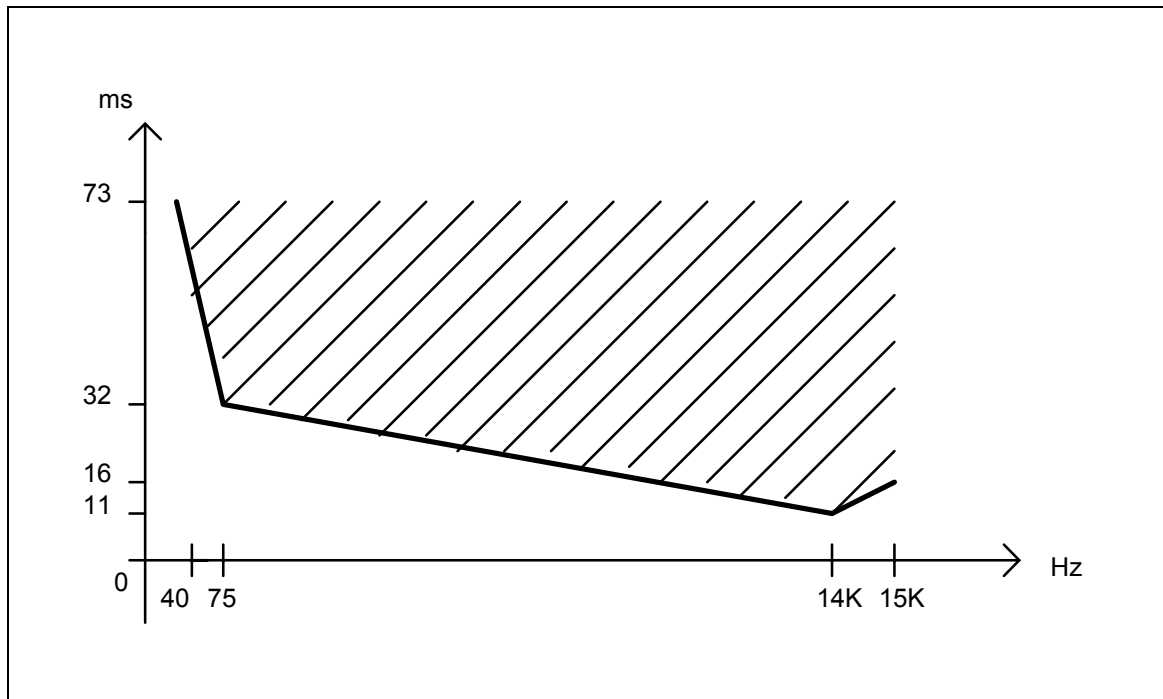

Monophonic 15 kHz sound-programme quality broadband link - Maximum group delay distortion values according to frequency

Appendix 5: Special characteristics of stereophonic 15 kHz sound-programme quality broadband links

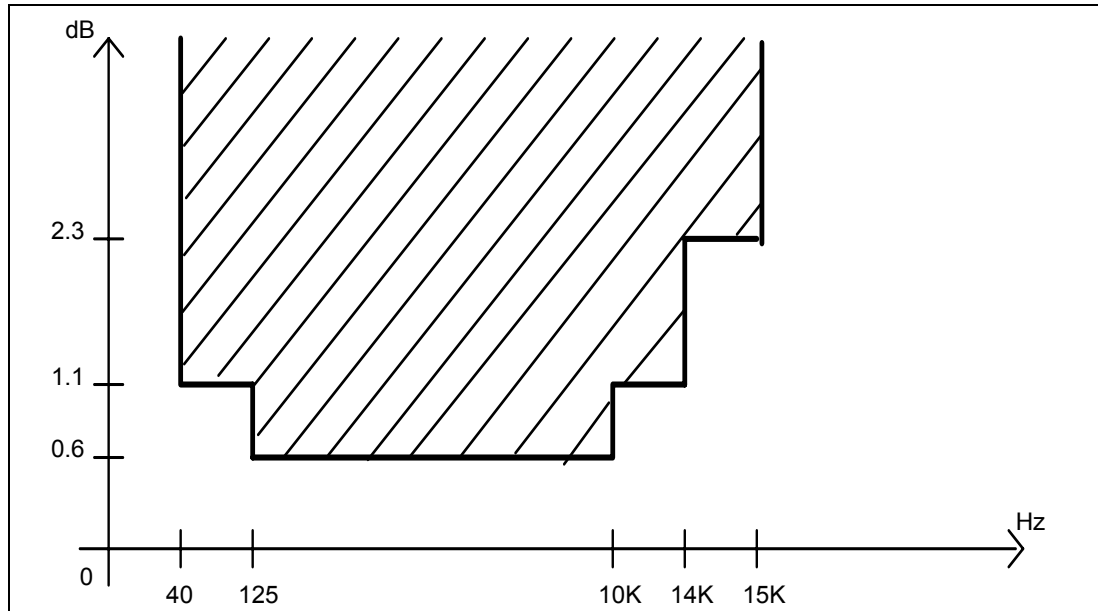

Gain difference tolerance for 15 kHz stereophonic channels A and B

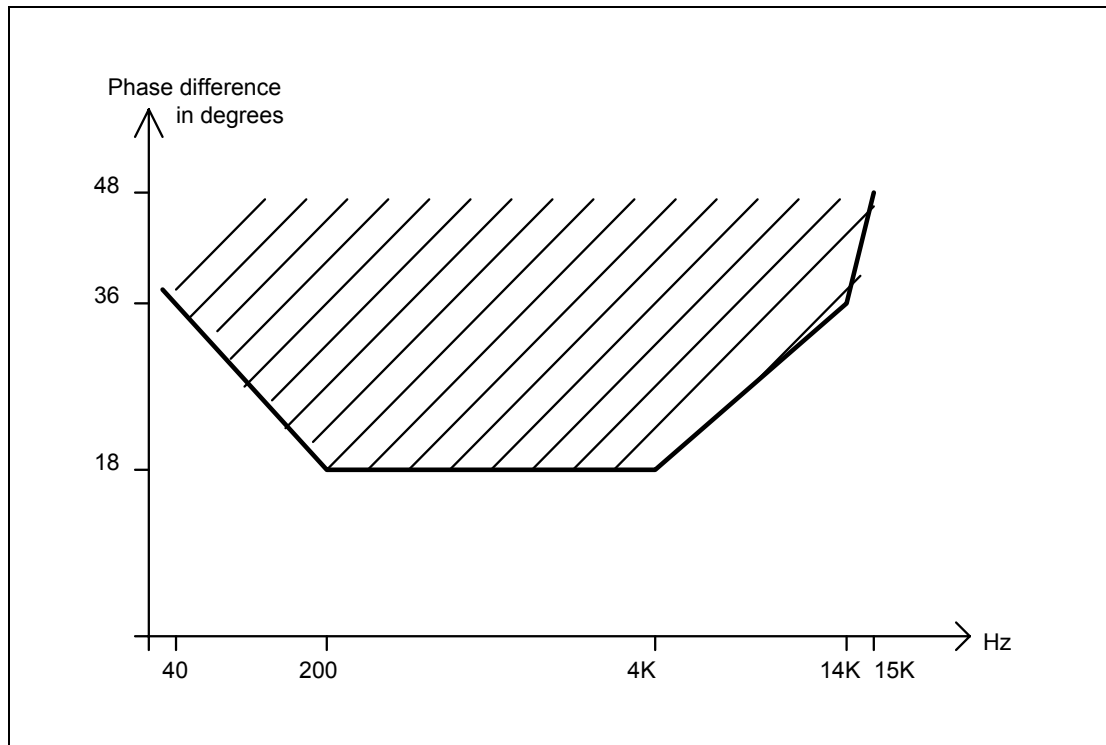

Phase difference between stereophonic channels A and B